

SH90WB 5 + 6 GHz Wideband 90° Symmetrical Horn

Sector Horn Antenna For High-Density Multiband Fixed Wireless Networks

The SH90WB Symmetrical Horn Antenna delivers high-performance wideband coverage in a compact and durable design. Engineered for operation across both 5 GHz and 6 GHz bands, it provides a symmetrical radiation pattern with equal beamwidth in the horizontal and vertical planes, ensuring uniform and predictable coverage.

With naturally suppressed side lobes and controlled beam characteristics, SH90WB offers excellent interference rejection and improved signal-to-noise ratio (SNR) in dense deployments. This makes it particularly well suited for high-density sector applications.

The wideband design supports stable gain, consistent beam shape, and low VSWR across the entire 4900–7125 MHz frequency range. This enables flexible deployment strategies, including 5 GHz-only, 6 GHz-only, and combined wideband operation incl. WiFi 7 outdoor and indoor/industrial deployments, without the need for antenna replacement.

Built for long-term outdoor use, SH90WB features a lightweight yet robust construction using extruded aluminum and high-quality materials. The antenna is designed for reliability in harsh environmental conditions, including coastal and high-wind installations.

SH90WB is an ideal choice for operators seeking scalable, interference-resilient infrastructure that supports modern wideband and high-capacity wireless networks.



TECHNICAL DATA

Radio Connection	TwistPort™ Waveguide Connector
Antenna Type	Horn
Materials	UV Resistant ABS plastic, Aluminium, Stainless Steel
Environmental	IP65
Pole Mounting Diameter	40-80 mm (1.5-3.1 inch) Recommended as close to 80 mm (3.1 inch) as possible
Temperature	-35°C to +60°C (-31°F to +140°F)
Wind Survival	160 km/h (100 mph)
Wind Load	22/11 N - Front/Side at 160 km/h (100 mi/h)
Effective Projected Area	183/90 cm ² - Front/Side (32.8/12.5 in ²)
Mechanical Adjustment	± 20° Elevation, ± 20° Azimuth
Weight	1.7 kg / 3.7 lbs – single unit 2.8 kg / 6 lbs – single unit incl. package 15.3 kg / 34 lbs – wholesale box (5 units)
Dimensions	Single unit retail box: 290 × 230 × 240 mm (11 × 9 × 9 inch) Wholesale box (5 units): 1000 × 305 × 270 mm (47 × 12 × 10 inch)

PRODUCT DIMENSIONS

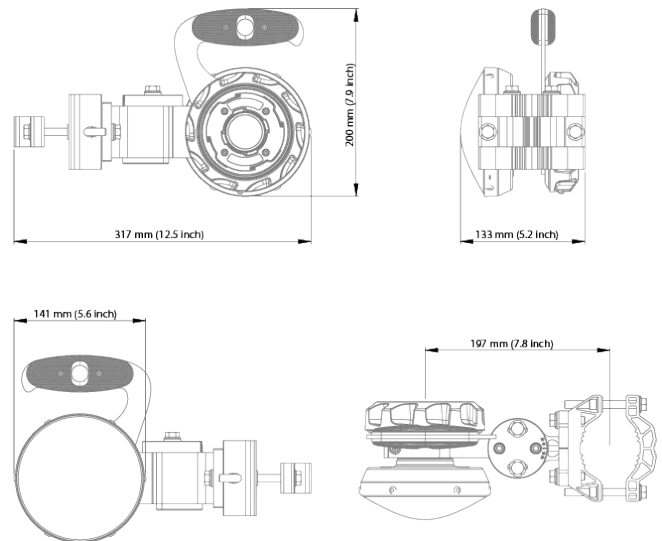

PERFORMANCE

Frequency Range	4900 - 7200 MHz
Gain	11 dBi
Azimuth Beam Width -3 dB/-6dB	H 64°, V 61° / H 86°, V 85°
Elevation Beam Width -3 dB/-6dB	H 61°, V 63° / H 85°, V 85°
Beam Efficiency	93 %*
Front-to-Back Ratio	30 dB
VSWR	<1.8
Polarization	Dual Linear H + V
Impedance	50 Ohm

* Beam efficiency defined up to first null

Product Datasheet

Product ID: SH90WB

ANTENNA GAIN

Antenna Nominal Gain with Waveguide Port

This graph demonstrates the maximum achievable gain of the antenna in boresight with an ideal waveguide port.

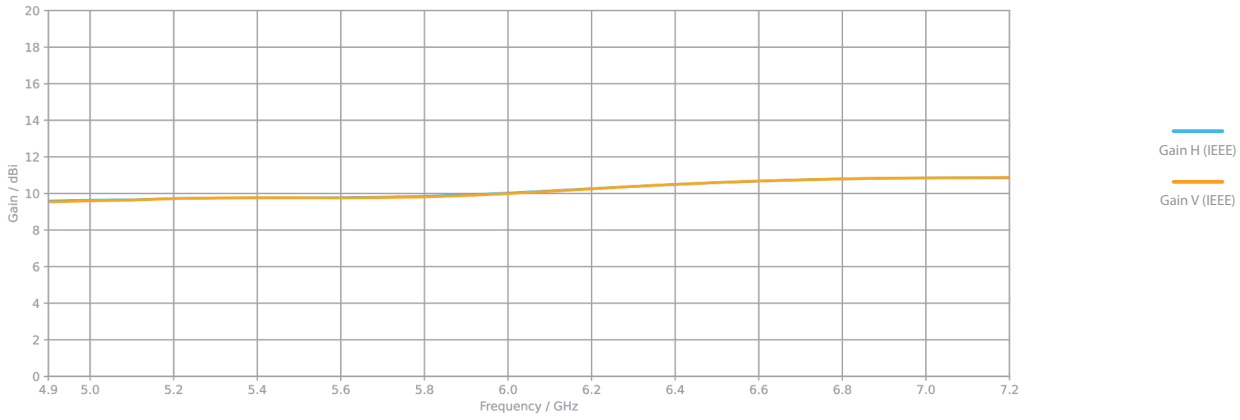

ANTENNA BEAMWIDTH

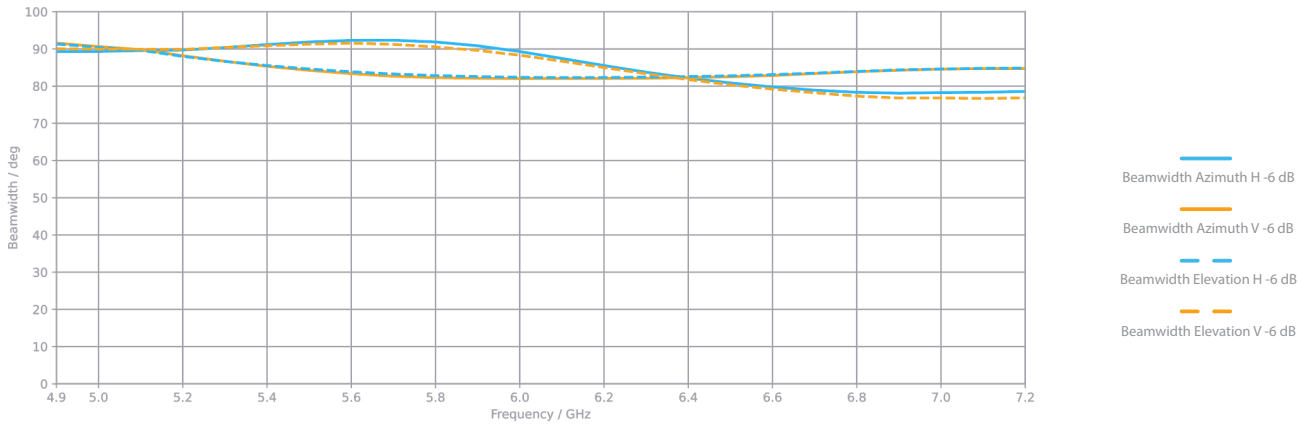

RADIATION PATTERNS

